

LOCATE HYDRANT SO THAT DRIVE IS NOT BLOCKED WHEN CONNECTED. CONNECTION IS ON THE SIDE OF THE TRUCK. SEE SPACING DETAIL, DWG 3

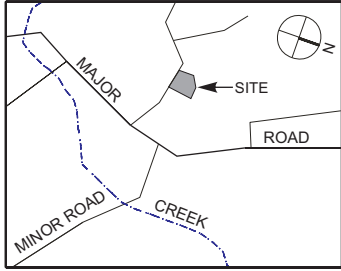

VICINITY MAP

PROJECT NAME  
PROJECT ADDRESS, CITY  
APPLICANT NAME  
APPLICANT PHONE  
PERMIT NO

ALL WEATHER SURFACE  
SEC 13-30

DRIVEWAY/ROAD GRADE  
< 15%, SEC 13-31

DRIVE LENGTH, SEC 13-37

ROAD CLEARANCE FROM  
VEGETATION, SEC 13-56

30' MIN OR  
TABLE 13-55

BARN  
1,000 SF

60'-150'  
SEC 13-52(c)(2)

TURNAROUND, SEC 13-37(c)  
DWG 8

GATE, SEC 13-38

ADDRESS SIGN  
SEC 13-48(b)

WIDTH AS REQUIRED  
BY SEC 13-33 TO 13-38

RADIUS - SECTION 13-32(c)

DISTANCE TO PUBLIC HYDRANT  
WHERE APPLICABLE  
SEC 13-52

60'-150'  
SEC 13-52(c)(2)

60' MIN. CLR

30' OR MORE  
PER TABLE 13-55  
TYPICAL TO  
PROP. LINES

SINGLE  
FAMILY  
RESIDENCE

TURNAROUND WITHIN 150' OF  
EACH STRUCTURE,  
SEC 13-37(c) OR  
HAMMERHEAD/T - DWG 9

RADIUS  
DWG 10

4" MIN SUPPLY PIPING,  
SEC 13-52(c)(1)

TURNOUT, SEC 13-37(b)  
NON COMBUSTIBLE TANK IF  
INSIDE MIN SETBACK, 20' VEG  
CLEARANCE IF POLY OR SIM.

WATER STORAGE TANK

20' MIN TO PROPERTY LINE  
OR TABLE 13-55

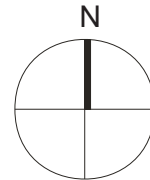

PROPERTY LINE

ROAD NAME

SAMPLE SITE PLAN

SONOMA COUNTY  
FIRE AND EMERGENCY SERVICES DEPARTMENT

2300 COUNTY CENTER DR  
Santa Rosa, California 95403  
Telephone (707) 565-1152 Fax (707) 565-1172

FIRE SAFE STANDARDS

1" = 50'

SCALE

01/19/17

REVISION DATE

F1

DRAWING NO

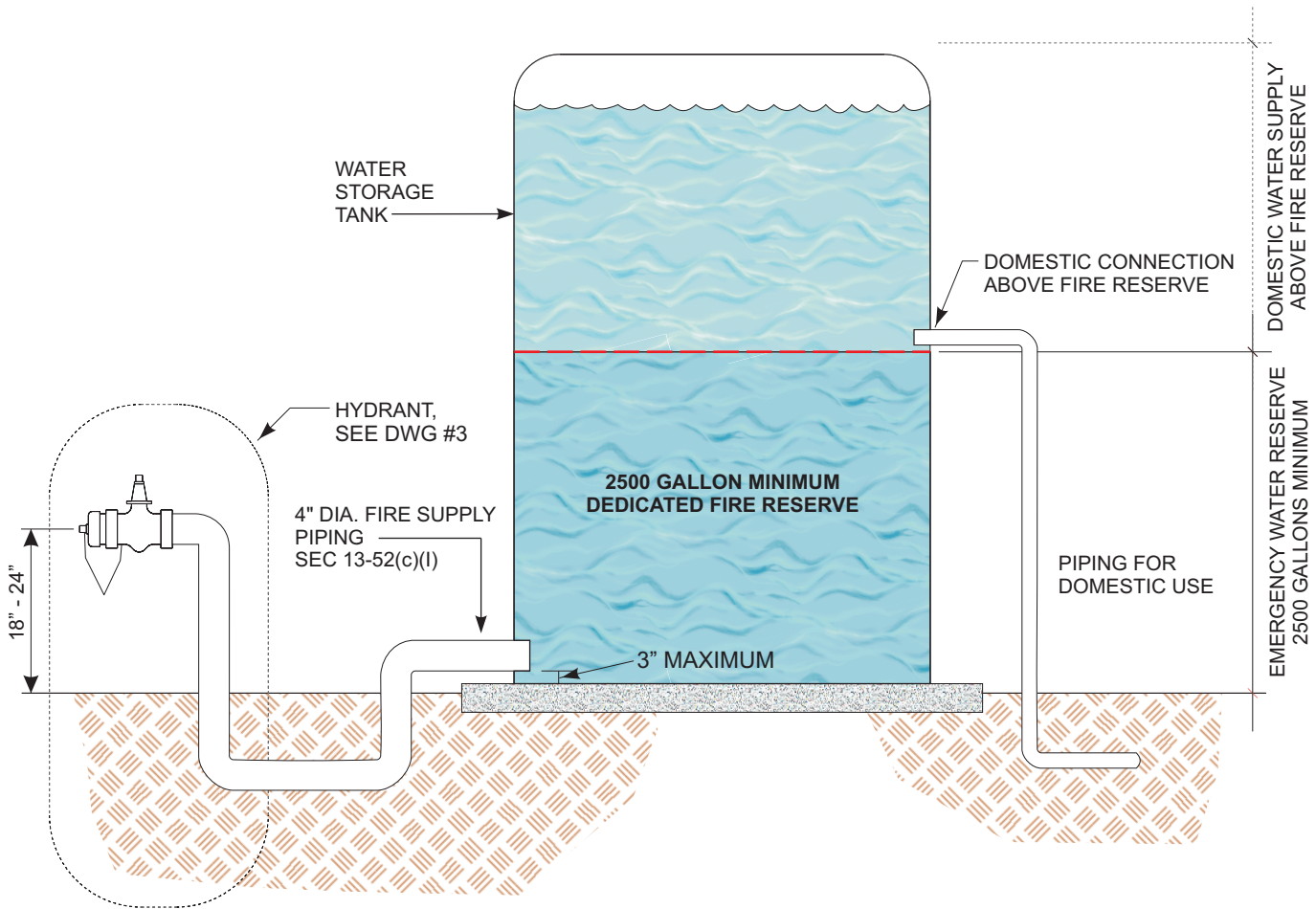

- FOR STORAGE CAPACITY REQUIREMENTS, REFER TO SEC 13-51(b) & 13-52(b)
- WHEN MULTIPLE TANKS ARE UTILIZED TO ACHIEVE THE REQUIRED VOLUME OF WATER, THE CONNECTION BETWEEN THE TANKS SHALL BE BY AN APPROVED 4" DIA. WATER LINE

**SEC 13-51 EMERGENCY WATER SUPPLY**

**SONOMA COUNTY**  
**FIRE AND EMERGENCY SERVICES DEPARTMENT**  
 2300 COUNTY CENTER DR  
 Santa Rosa, California 95403  
 Telephone (707) 565-1152 Fax (707) 565-1172

**FIRE SAFE STANDARDS**

NOT TO SCALE

SCALE

01/19/17

REVISION DATE

**F2**

DRAWING NO

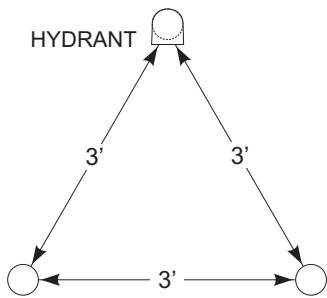

**HYDRANT AND POST/BOLLARD  
TYPICAL SPACING**

GUARD POSTS WHERE SHOWN

3" BLUE REFLECTOR AT BOLLARD AND AT ADDRESS

3" DIA. STEEL PIPE, CONC FILLED

FINISHED GRADE

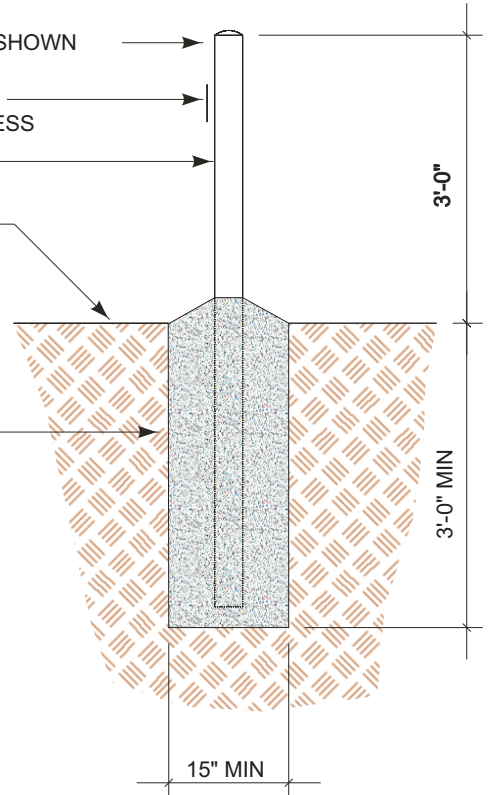

UNREINFORCED CONC ENCASEMENT

**GUARD POST/BOLLARD  
SEC. 13-52(e), 13-53**

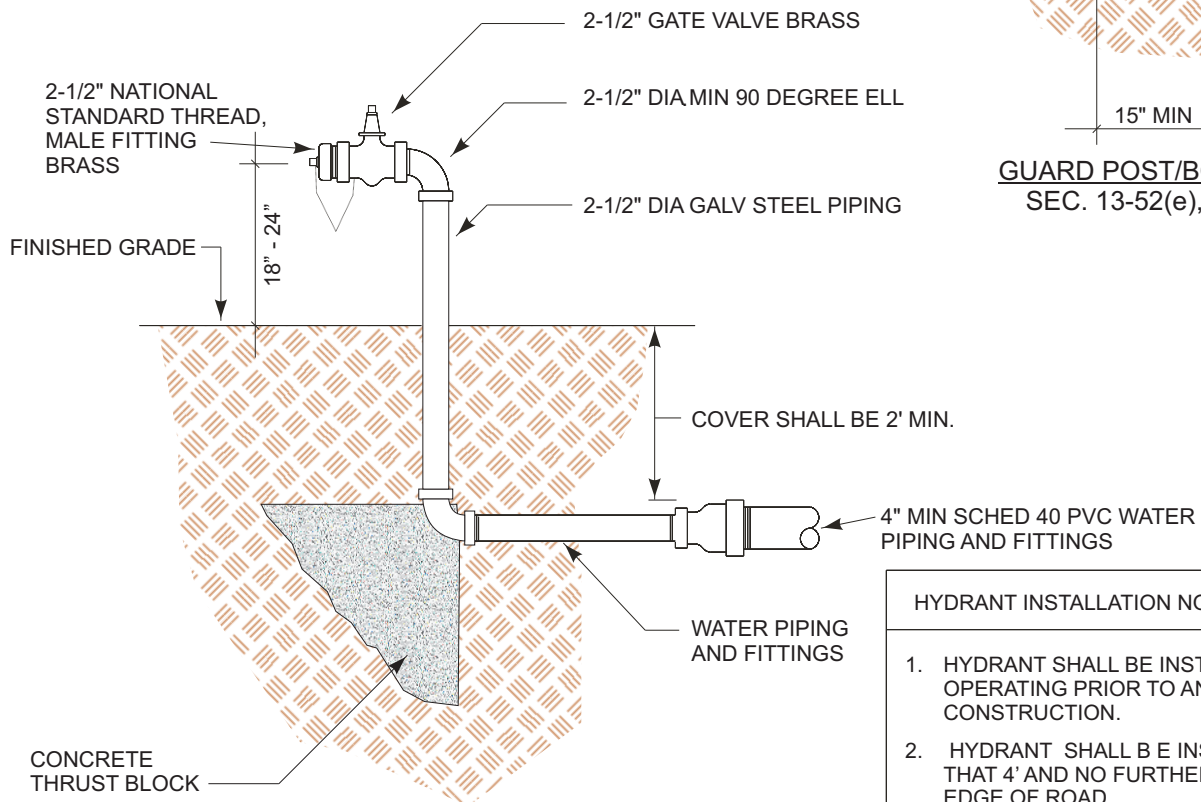

**FIRE DEPT. HYDRANT  
SEC. 13-52**

**HYDRANT INSTALLATION NOTES**

1. HYDRANT SHALL BE INSTALLED AND OPERATING PRIOR TO AND DURING CONSTRUCTION.
2. HYDRANT SHALL BE INSTALLED NO CLOSER THAN 4' AND NO FURTHER THAN 12' FROM EDGE OF ROAD.
3. WHERE HYDRANT IS PROVIDED AT ROAD OR DRIVEWAY LESS THAN 20' IN WIDTH, A TURNOUT SHALL BE PROVIDED AT HYDRANT LOCATION. SEE DRAWING 7.

**SEC 13-52 FIRE DEPT HYDRANT/GUARD POSTS**

**SONOMA COUNTY  
FIRE AND EMERGENCY SERVICES DEPARTMENT**  
2300 COUNTY CENTER DR  
Santa Rosa, California 95403  
Telephone (707) 565-1152 Fax (707) 565-1172

**FIRE SAFE STANDARDS**

1/2" = 1'-0"

SCALE

01/19/17

REVISION DATE

**F3**

DRAWING NO

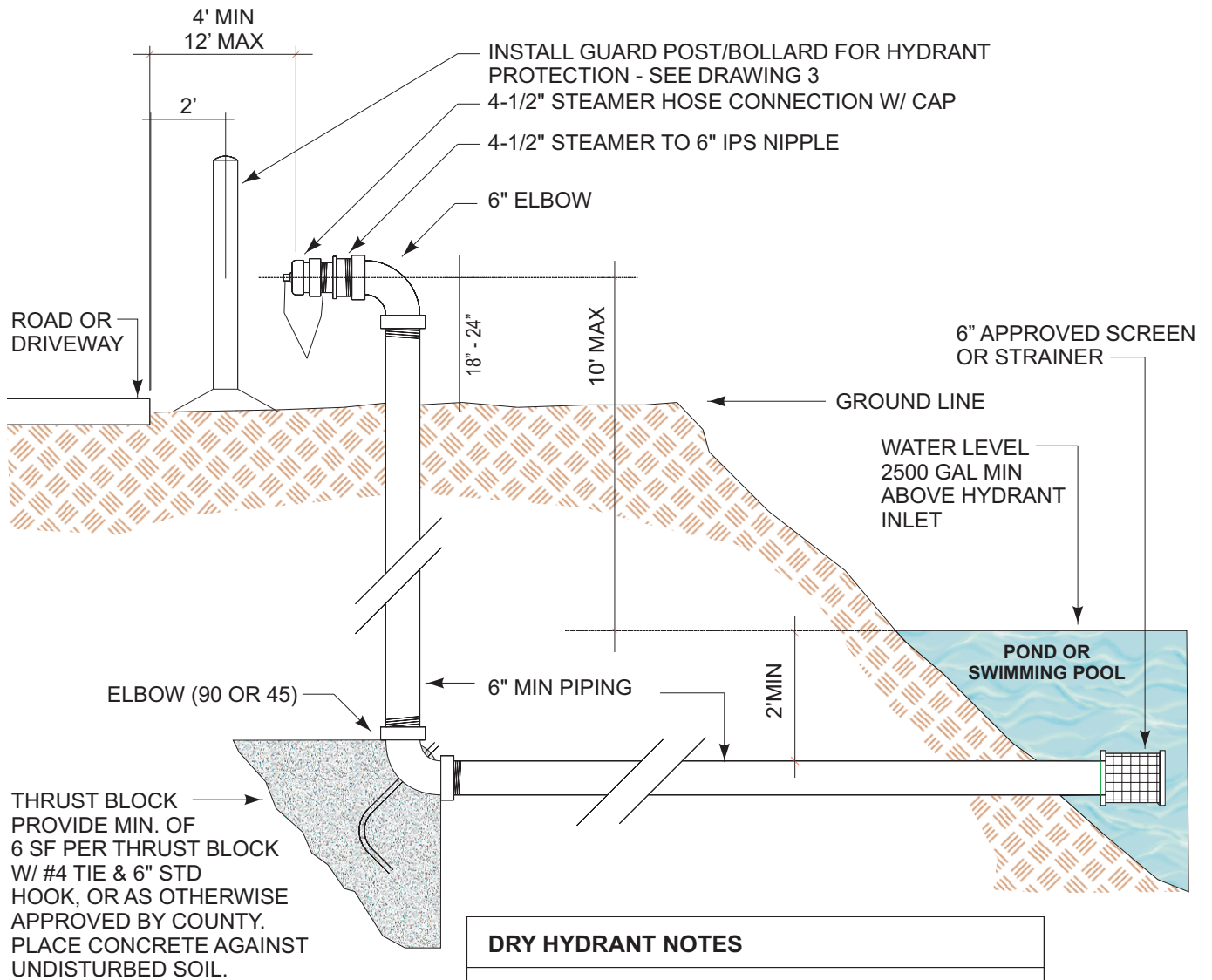

**DRY HYDRANT NOTES**

1. PIPING MAY BE IRON, STEEL OR PVC SCHEDULE 40 MIN.
2. **USE SIMILAR HYDRANT CONFIGURATION FOR SWIMMING POOL AS WATER SOURCE.**
3. SCREEN OR STRAINER PER NFPA APPENDIX B-5.3.1.1(f)
4. SHALL HAVE SIGN STATING POOL OR POND

SEC 13-52(e) DRY OR DRAFT HYDRANT

**SONOMA COUNTY**  
**FIRE AND EMERGENCY SERVICES DEPARTMENT**  
 2300 COUNTY CENTER DR  
 Santa Rosa, California 95403  
 Telephone (707) 565-1152 Fax (707) 565-1172

FIRE SAFE STANDARDS

1/2" = 1'-0"

SCALE

01/19/17

REVISION DATE

**F4**

DRAWING NO

**ALL BRIDGES**

- HS 20 LOADING [SEC 13-33(a)]
- SIGNS INDICATING WEIGHT LIMIT AND VERTICAL CLEARANCE LIMITS [SEC 13-33 (b)]
- COMBINATION VEHICLE/PEDESTRIAN GUARD RAILS BOTH SIDES

BRIDGE WIDTH: 12' MAX.  
 LOAD: 80,000 LBS  
 CERT YEAR. XXXX

**ONE LANE BRIDGE**

- MINIMUM WIDTH: 12.0' [SEC 13-33(c)] EXCEPT DRIVEWAYS WITH MAXIMUM LENGTH OF 65' IN WHICH CASE MINIMUM WIDTH MAY BE 10.0'
- SIGNS INDICATING ONE WAY OR ONE LANE CONDITION [SEC 13-33 (b)]
- UNOBSTRUCTED VISIBILITY ENTIRE LENGTH [SEC 13-33(c)]
- TURNOUTS AT BOTH ENDS [SEC 13-33(c)]

SIGN EXAMPLE  
 NOT TO SCALE

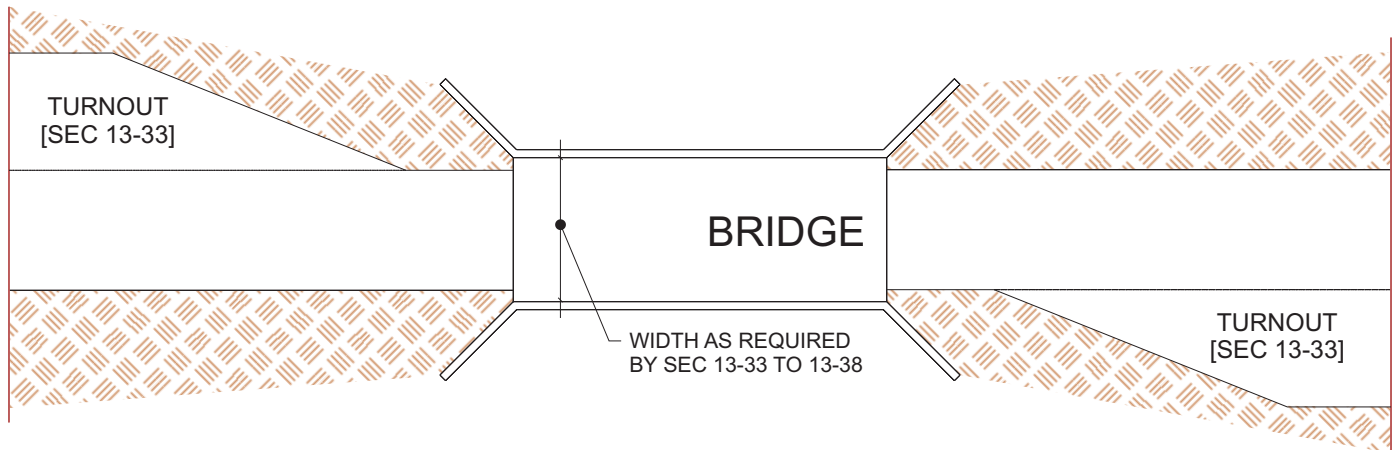

**SEC 13-33 BRIDGES**

**SONOMA COUNTY**  
**FIRE AND EMERGENCY SERVICES DEPARTMENT**  
 2300 COUNTY CENTER DR  
 Santa Rosa, California 95403  
 Telephone (707) 565-1152 Fax (707) 565-1172

**FIRE SAFE STANDARDS**

1/16" = 1'-0"

SCALE

01/19/17

REVISION DATE

**F5**

DRAWING NO

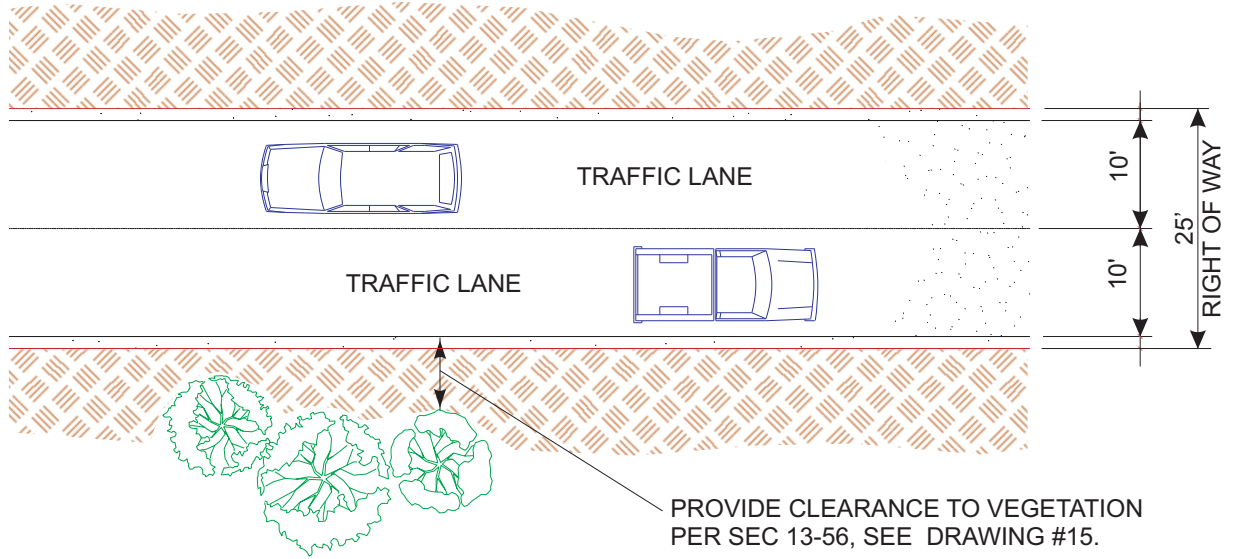

**TWO WAY ROAD**  
**SEC. 13-34**

- MINIMUM RIGHT OF WAY: 25'
- WIDTH AS REQUIRED BY SEC 13-33 TO 13-38



**DRIVEWAY**  
**SEC. 13-37**

- WIDTH AS REQUIRED BY SEC 13-33 TO 13-38
- DRIVEWAYS SERVE BUILDINGS
- ROADS SERVE PARCELS

**SEC 13-34 ROAD/SEC 13-37 DRIVEWAY**

**SONOMA COUNTY**  
**FIRE AND EMERGENCY SERVICES DEPARTMENT**  
 2300 COUNTY CENTER DR  
 Santa Rosa, California 95403  
 Telephone (707) 565-1152 Fax (707) 565-1172

**FIRE SAFE STANDARDS**

1/16" = 1'-0"

SCALE

01/19/17

REVISION DATE

**F6**

DRAWING NO

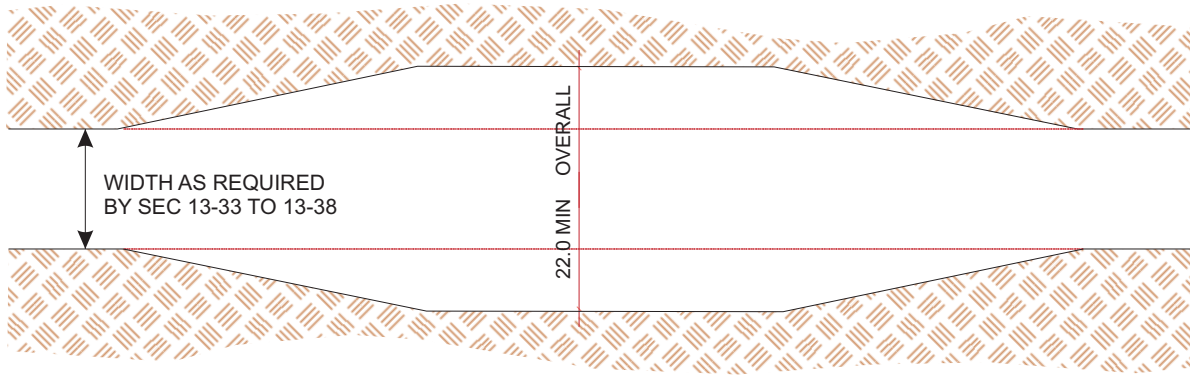

**BULGE TURNOUT**

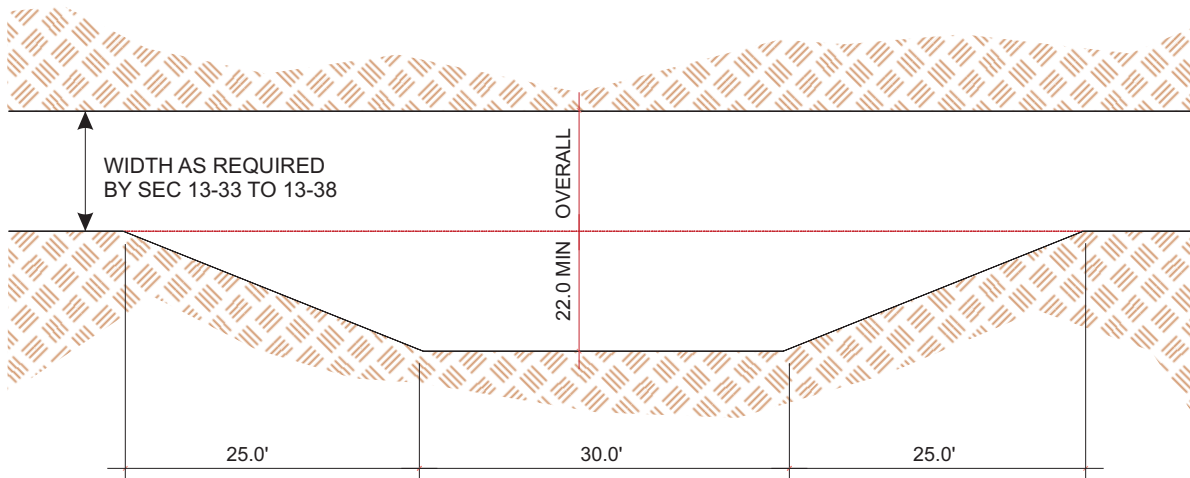

**TURNOUT**

[SEC 13-37(b)] ALL DRIVEWAYS EXCEEDING ONE HUNDRED FIFTY (150) FEET IN LENGTH SHALL HAVE A TURNOUT CONSTRUCTED AT APPROXIMATELY THE MIDPOINT OF THE DRIVEWAY. ANY DRIVEWAY EXCEEDING EIGHT HUNDRED (800) FEET IN LENGTH SHALL HAVE TURNOUTS CONSTRUCTED APPROXIMATELY EVERY FOUR HUNDRED (400) FEET ALONG THE ENTIRE LENGTH OF THE DRIVEWAY.

[SEC 13-35(c)] ALL ONE-WAY ROADS EXCEEDING FIVE HUNDRED (500') IN LENGTH SHALL HAVE A TURNOUT CONSTRUCTED AT APPROXIMATELY THE MIDPOINT OF THE ROAD. ANY ONE-WAY ROAD EXCEEDING ONE THOUSAND FEET (1000') IN LENGTH SHALL ALSO HAVE TURNOUTS CONSTRUCTED APPROXIMATELY EVERY FIVE HUNDRED FEET (500') ALONG THE ENTIRE LENGTH OF THE ROAD.

**SEC 13-37(b) & SEC 13-35(c) TURNOUT**

**SONOMA COUNTY**  
**FIRE AND EMERGENCY SERVICES DEPARTMENT**  
 2300 COUNTY CENTER DR  
 Santa Rosa, California 95403  
 Telephone (707) 565-1152 Fax (707) 565-1172

**FIRE SAFE STANDARDS**

1/16" = 1'-0"

SCALE

01/19/17

REVISION DATE

**F7**

DRAWING NO

SLOPE ON TURNAROUNDS SHALL NOT EXCEED 8%

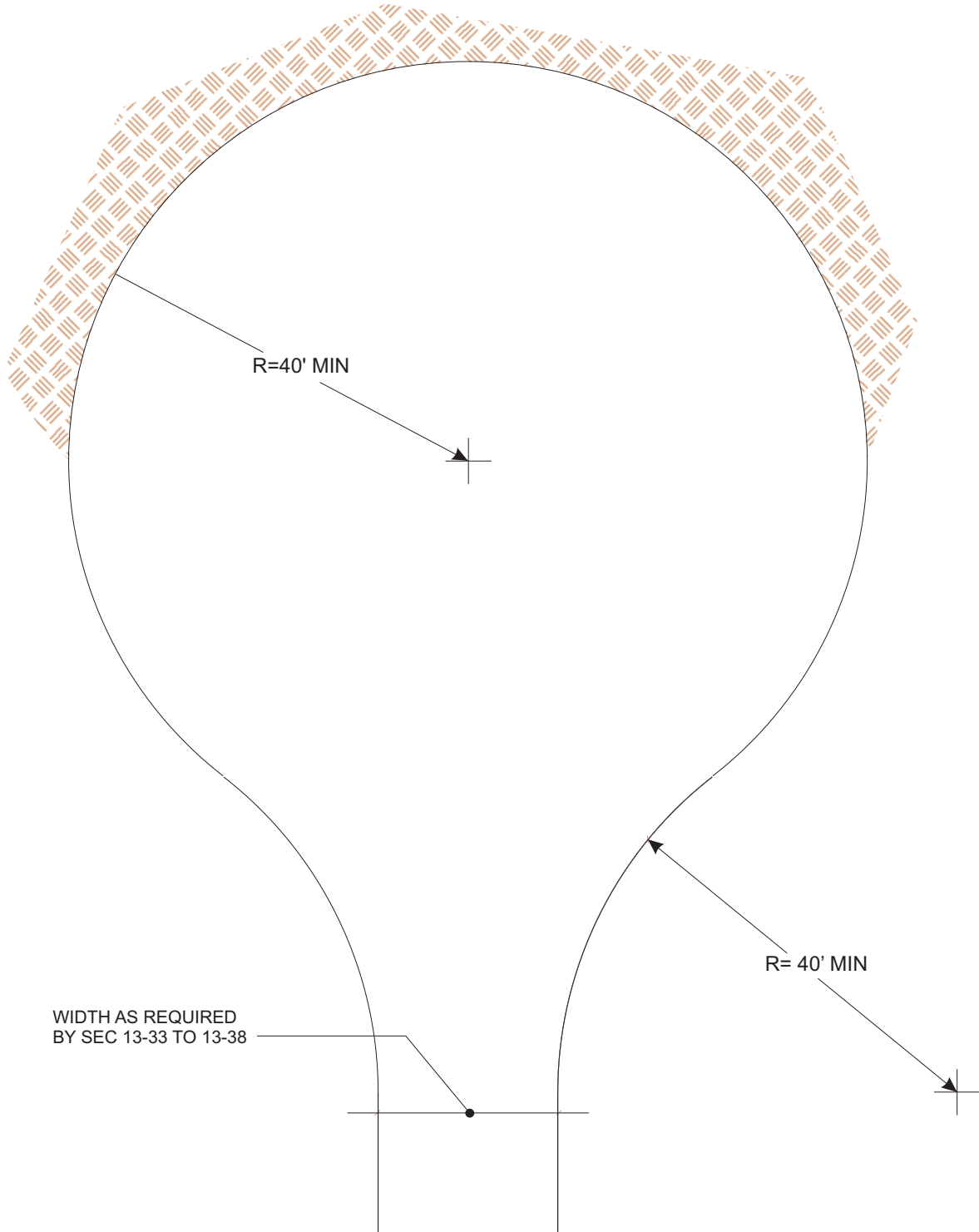

BULB TURNAROUND  
Option #1

SEC 13-37(c) & 13-36(b),(c) TURNAROUND

**SONOMA COUNTY**  
**FIRE AND EMERGENCY SERVICES DEPARTMENT**  
2300 COUNTY CENTER DR  
Santa Rosa, California 95403  
Telephone (707) 565-1152 Fax (707) 565-1172

FIRE SAFE STANDARDS

1/16" = 1'-0"

SCALE

01/19/17

REVISION DATE

**F8**

DRAWING NO



SLOPE ON TURNAROUNDS SHALL NOT EXCEED 8%

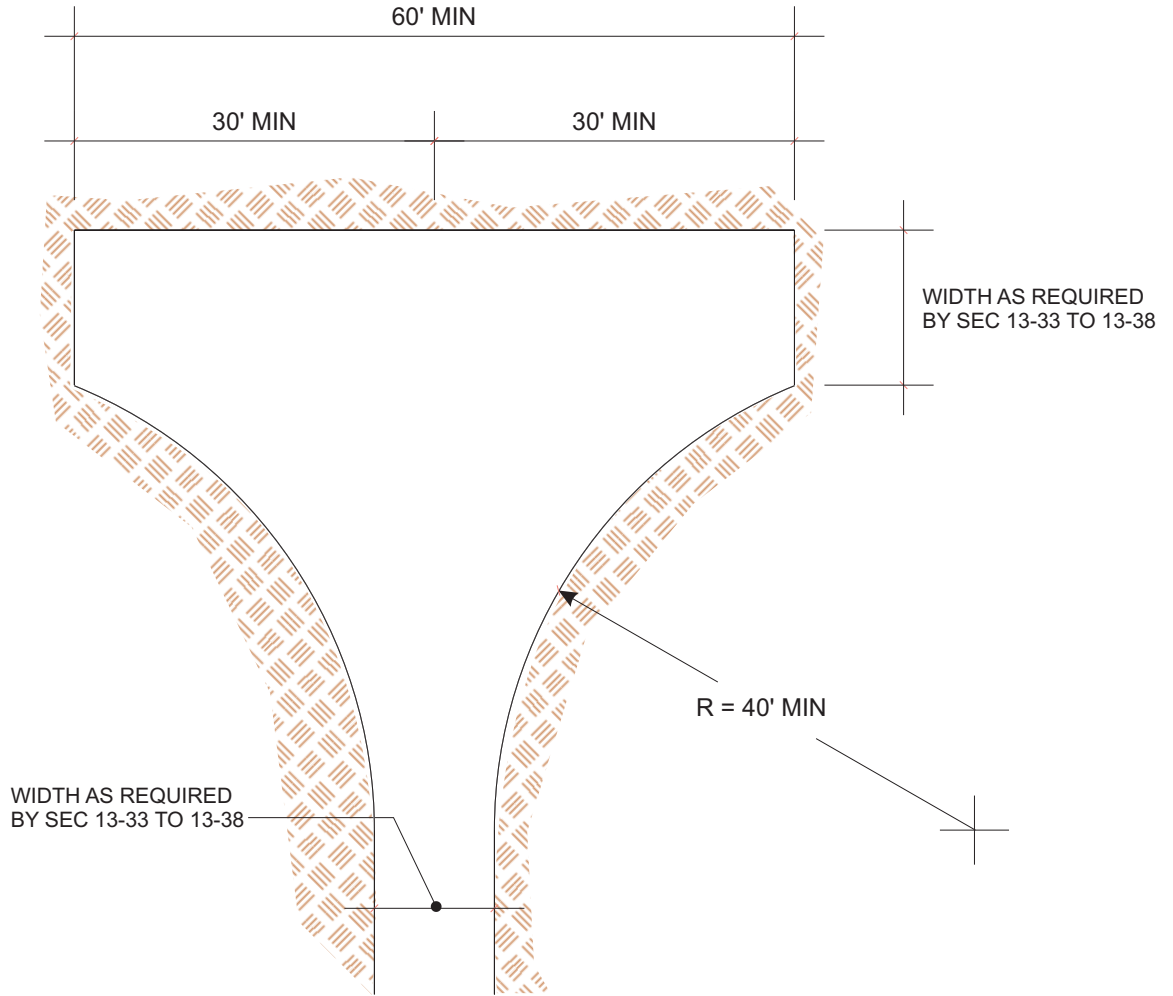

HAMMERHEAD TURNAROUND  
Option #2

SEC 13-37(c) & 13-36(b),(c) HAMMERHEAD/T

**SONOMA COUNTY**  
**FIRE AND EMERGENCY SERVICES DEPARTMENT**  
2300 COUNTY CENTER DR  
Santa Rosa, California 95403  
Telephone (707) 565-1152 Fax (707) 565-1172

FIRE SAFE STANDARDS

1/16" = 1'-0"

SCALE

01/19/17

REVISION DATE

**F9**

DRAWING NO

SLOPE ON TURNAROUNDS SHALL NOT EXCEED 8%

WIDTH AS REQUIRED  
BY SEC 13-33 TO 13-38

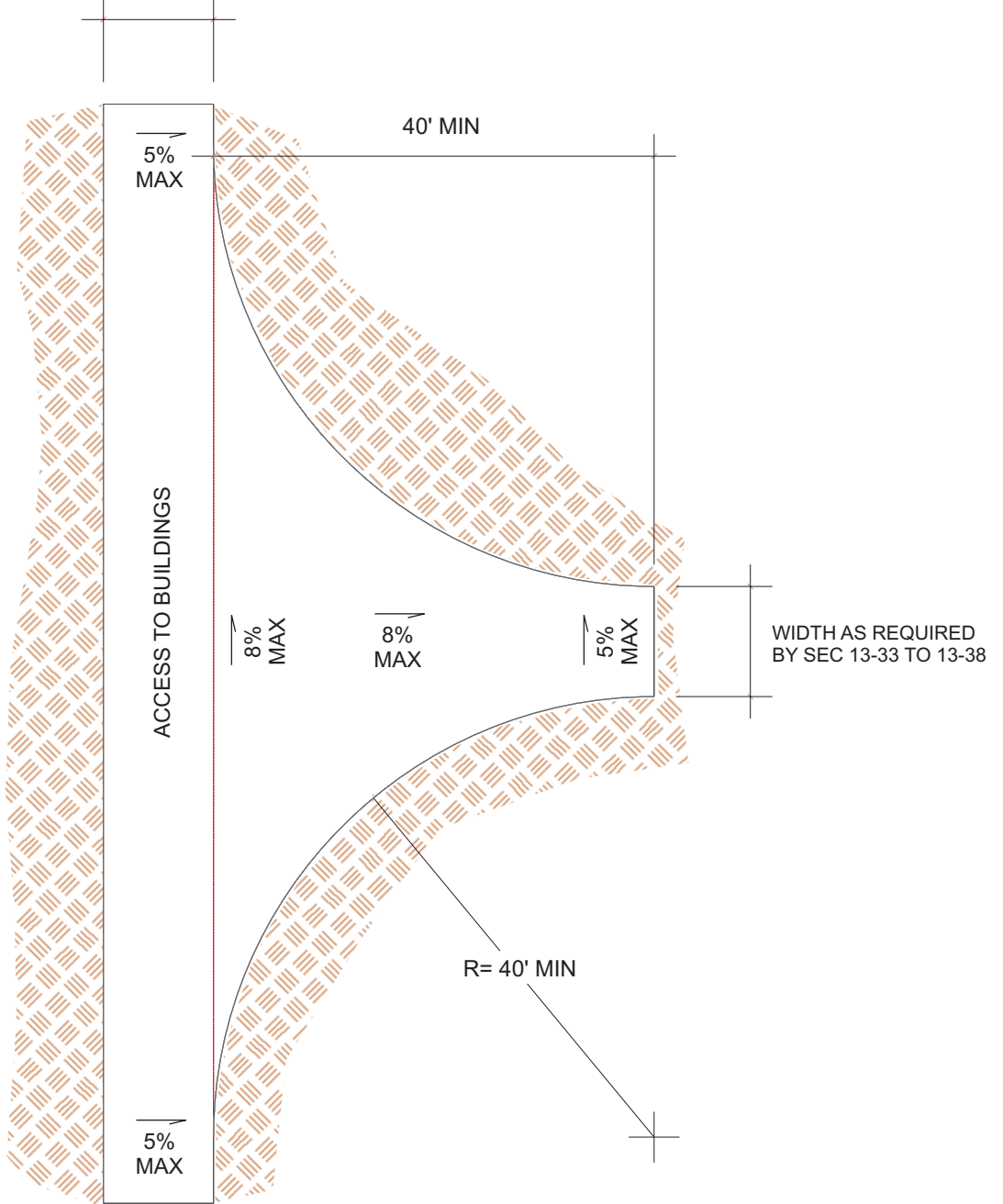

**STUB-OUT TURNAROUND**  
Option #3

SEC 13-31, SEC 13-37(c) & 13-36(b), (c) TURNAROUND

FIRE SAFE STANDARDS

**SONOMA COUNTY**  
**FIRE AND EMERGENCY SERVICES DEPARTMENT**  
2300 COUNTY CENTER DR  
Santa Rosa, California 95403  
Telephone (707) 565-1152 Fax (707) 565-1172

1/16" = 1'-0"

SCALE

01/19/17

REVISION DATE

**F10**

DRAWING NO

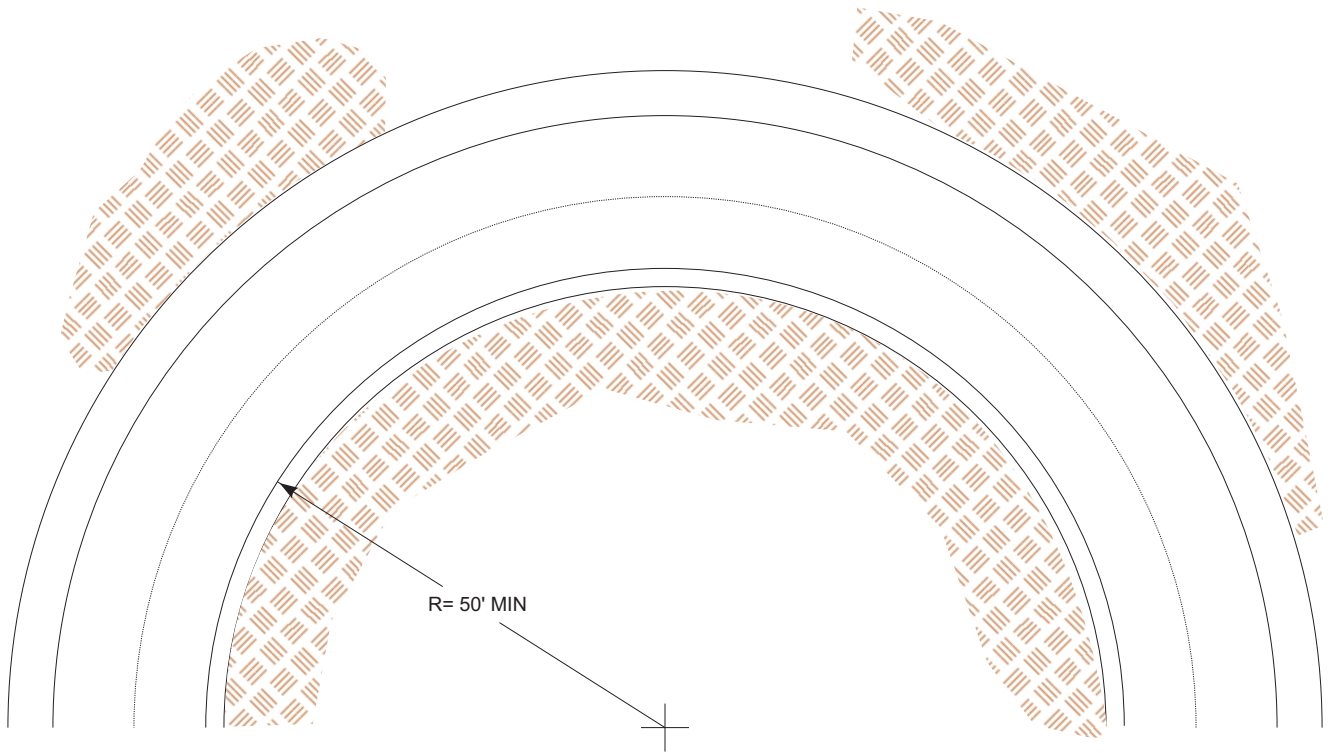

HORIZONTAL CURVE TURNING RADIUS, ROAD/DRIVEWAY  
SECTION 13-32

- HORIZONTAL INSIDE RADIUS 50' MIN
- ADDITIONAL WIDTHS ARE REQUIRED:
  - 4' IF RADIUS IS LESS THAN 100' AND A CENTRAL ANGLE > 45 DEGREES
  - 2' IF RADIUS IS 100' TO 200' AND A CENTRAL ANGLE > 45 DEGREES
- TURNOUTS ARE NOT ALLOWED ON THE INSIDE OF CURVES.

SEC 13-32, ROAD/DRIVEWAY CURVES

FIRE SAFE STANDARDS

**SONOMA COUNTY**  
**FIRE AND EMERGENCY SERVICES DEPARTMENT**  
2300 COUNTY CENTER DR  
Santa Rosa, California 95403  
Telephone (707) 565-1152 Fax (707) 565-1172

1/16" = 1'-0"

SCALE

01/19/17

REVISION DATE

**F11**

DRAWING NO

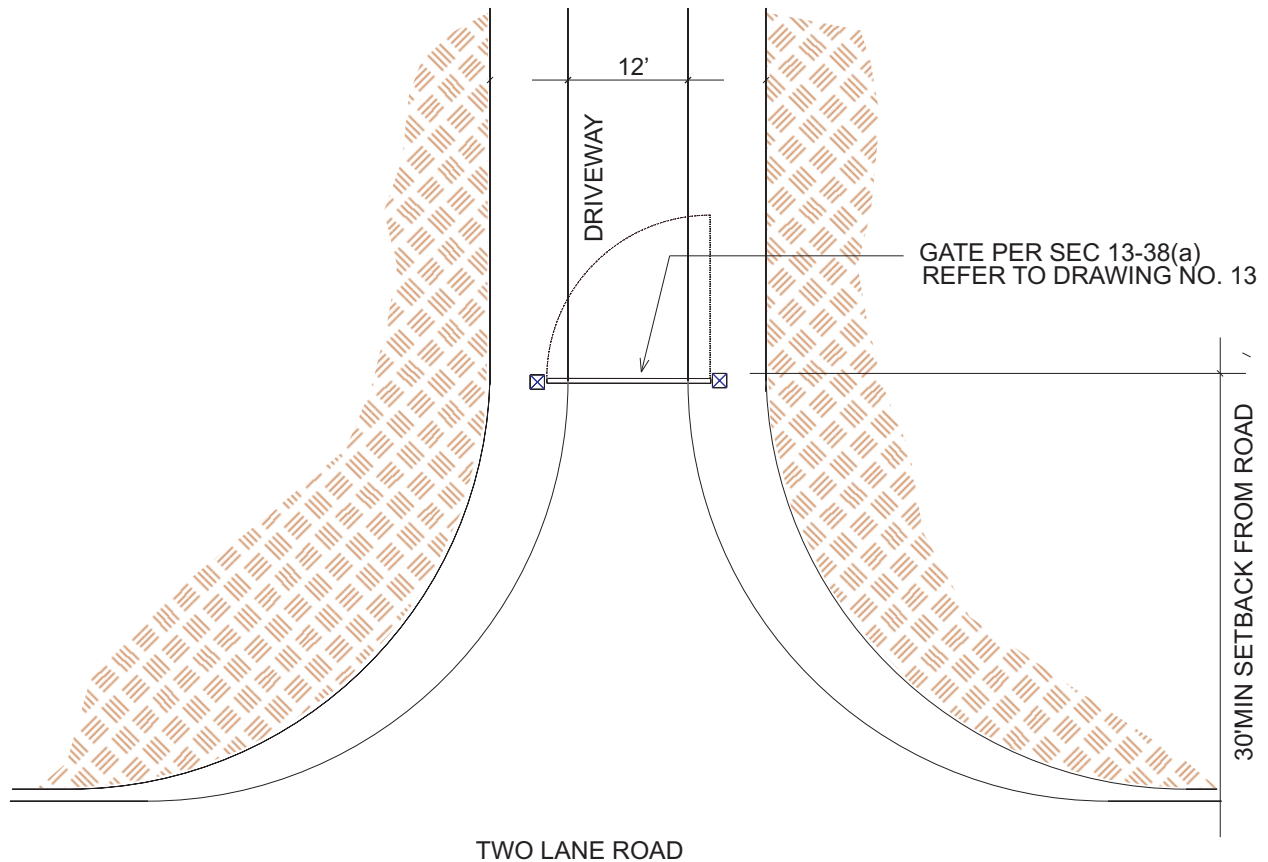

**GATED ENTRANCES  
SECTION 13-38**

- GATE ENTRANCE 2 FEET WIDER THAN WIDTH OF TRAFFIC LANE [SEC 13-28(a)]
- 30 FEET FROM THE ROADWAY, OPEN TO ALLOW A VEHICLE TO STOP WITHOUT OBSTRUCTING TRAFFIC [SEC 13-38(B)]
- PROVIDE FIRE DEPARTMENT APPROVED KEY ACCESS [13-38(D)]

**SEC 13-38 GATED ENTRANCES**

**SONOMA COUNTY  
FIRE AND EMERGENCY SERVICES DEPARTMENT**  
2300 COUNTY CENTER DR  
Santa Rosa, California 95403  
Telephone (707) 565-1152 Fax (707) 565-1172

**FIRE SAFE STANDARDS**

1/16" = 1'-0"

SCALE

01/19/17

REVISION DATE

**F12**

DRAWING NO

WIDTH AS REQUIRED BY SEC 13-33 TO 13-38

FIRE DEPARTMENT APPROVED KEY ACCESS  
CALL 565-1152 FOR ADDITIONAL INFORMATION

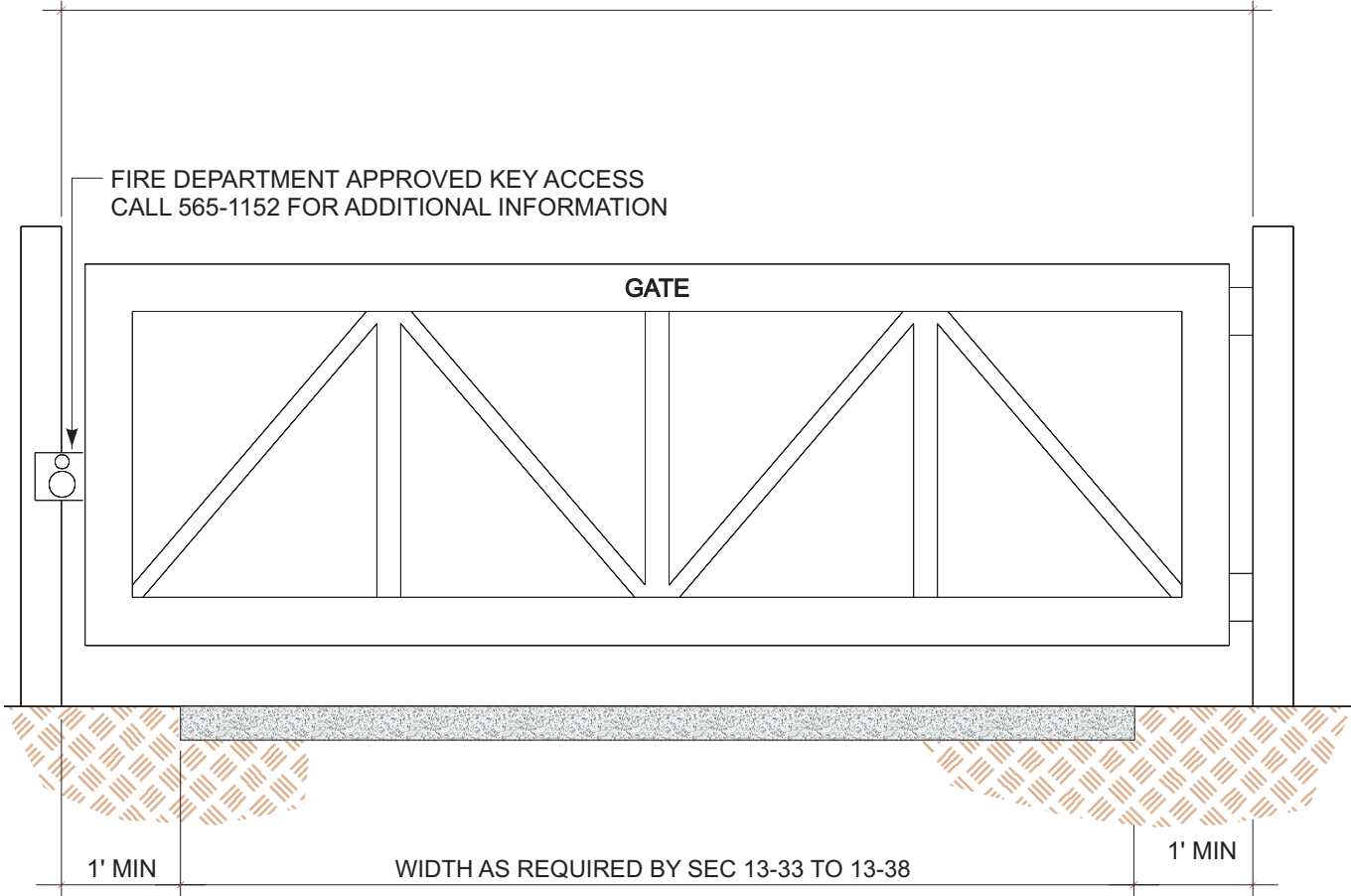

NOTE:  
GATE WIDTH SHALL BE NO LESS THAN WIDTH  
OF ROAD PLUS 1' SHOULDER, EACH SIDE OF ROAD

SEC 13-38 GATE

**SONOMA COUNTY**  
**FIRE AND EMERGENCY SERVICES DEPARTMENT**  
2300 COUNTY CENTER DR  
Santa Rosa, California 95403  
Telephone (707) 565-1152 Fax (707) 565-1172

FIRE SAFE STANDARDS

1/2" = 1'-0"

SCALE

01/19/17

REVISION DATE

**F13**

DRAWING NO

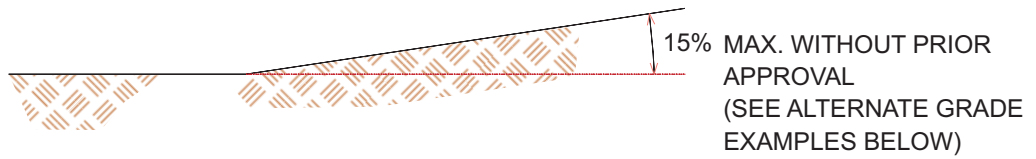

0% - 5% GRAVEL SURFACE: 1.00 FEET COMPACTED CLASS 2 AGGREGATE BASE [SEC 13-30(a)]

5% - 10% SEAL COAT SURFACE: DOUBLE SEAL COAT OVER 1.00 FEET COMPACTED CLASS 2 AGGREGATE BASE [SEC 13-30(b)]

OVER 10% ASPHALTIC CONCRETE SURFACE: 0.20 FEET ASPHALTIC CONCRETE OVER 0.50 FEET COMPACTED CLASS 2 AGGREGATE BASE [SEC 13-30(c)]

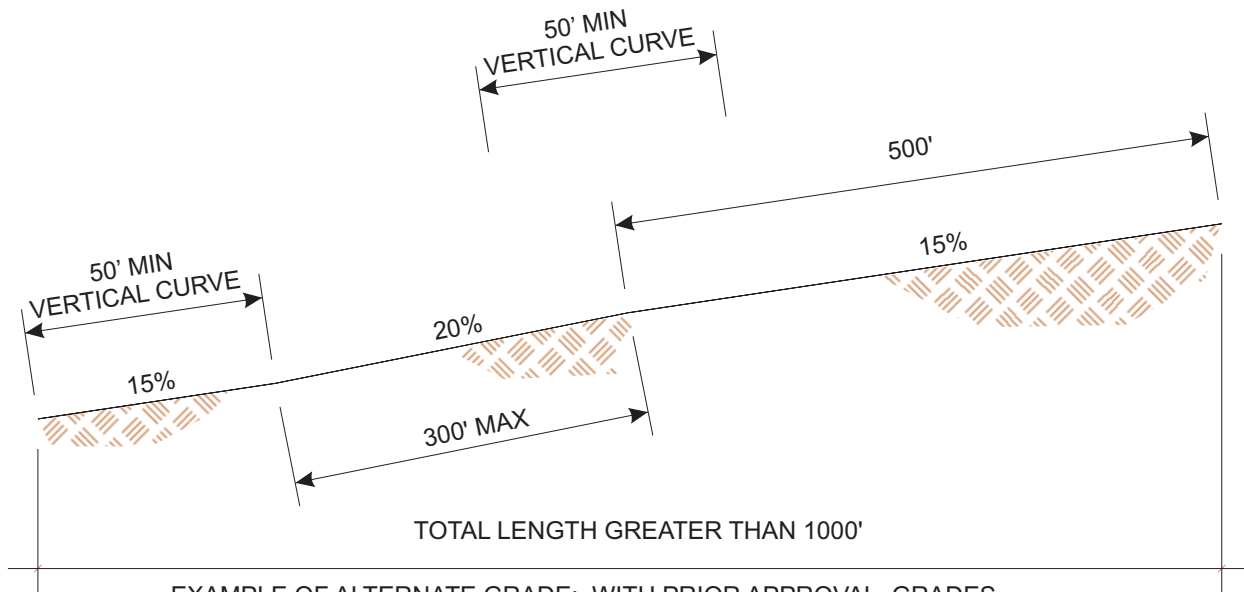

EXAMPLE OF ALTERNATE GRADE: WITH PRIOR APPROVAL, GRADES MAY BE UP TO 20% FOR DISTANCES NOT EXCEEDING 300' WITHIN ANY 1000' OF ROAD LENGTH.

GRADES & SURFACES  
SECTION 13-30 & 13-31

SEC 13-30 & 13-31 GRADES & SURFACES

FIRE SAFE STANDARDS

**SONOMA COUNTY**  
**FIRE AND EMERGENCY SERVICES DEPARTMENT**  
2300 COUNTY CENTER DR  
Santa Rosa, California 95403  
Telephone (707) 565-1152 Fax (707) 565-1172

NOT TO SCALE

SCALE

01/19/17

REVISION DATE

**F14**

DRAWING NO

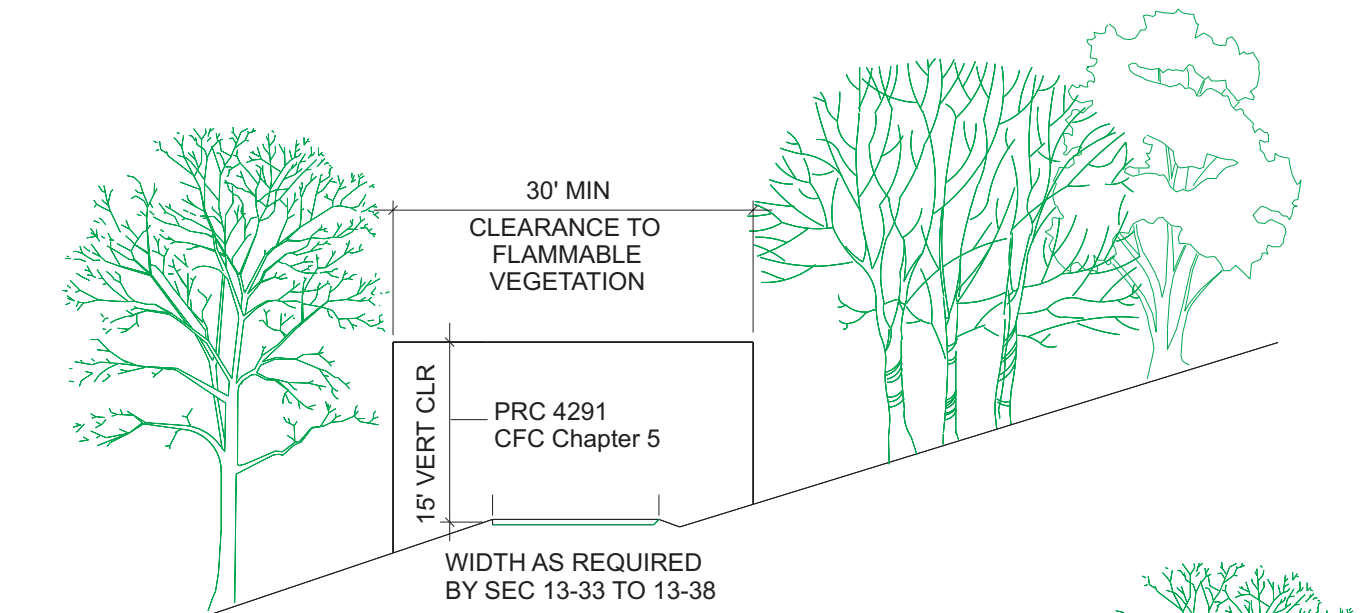

DRIVEWAY  
SEC 13-37

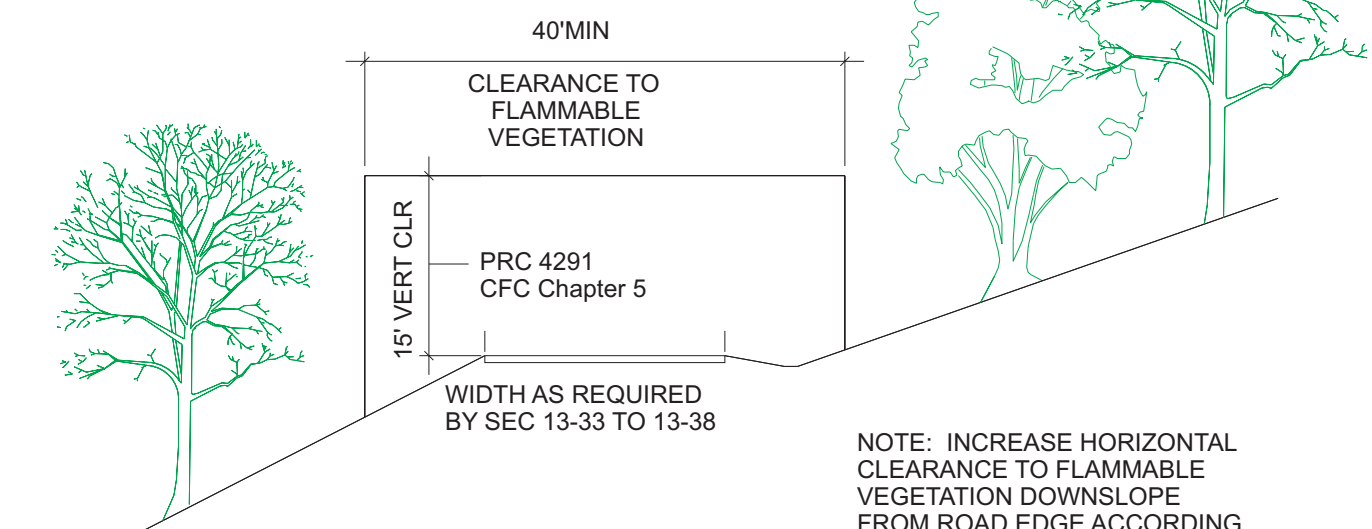

TWO WAY ROAD  
SEC 13-34

NOTE: INCREASE HORIZONTAL  
CLEARANCE TO FLAMMABLE  
VEGETATION DOWNSLOPE  
FROM ROAD EDGE ACCORDING  
TO THE FOLLOWING TABLE

0 - 10% SLOPE	10'
11 - 20% SLOPE	20'
30% + SLOPE	30'

SEC 13-34, 37 ROAD & DRIVE, VEGETATION CLEARANCE

FIRE SAFE STANDARDS

**SONOMA COUNTY**  
**FIRE AND EMERGENCY SERVICES DEPARTMENT**

2300 COUNTY CENTER DR  
Santa Rosa, California 95403  
Telephone (707) 565-1152 Fax (707) 565-1172

1/16" = 1'-0"

SCALE

01/19/17

REVISION DATE

**F15**

DRAWING NO

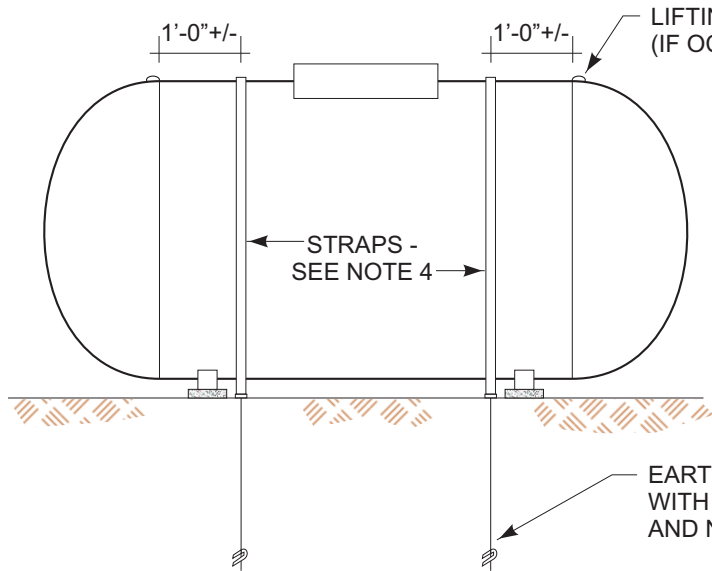

**351-1500 GALLON TANK ELEVATION  
2 STRAP PLACEMENT**

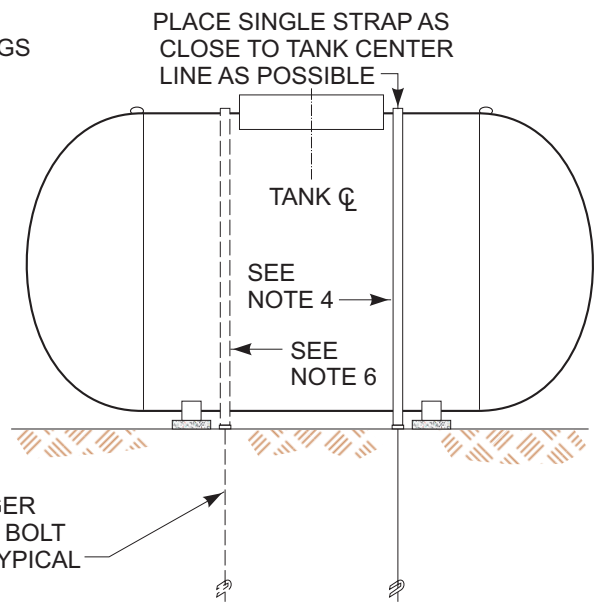

**UP TO 350 GALLON TANK ELEVATION  
1 STRAP PLACEMENT**

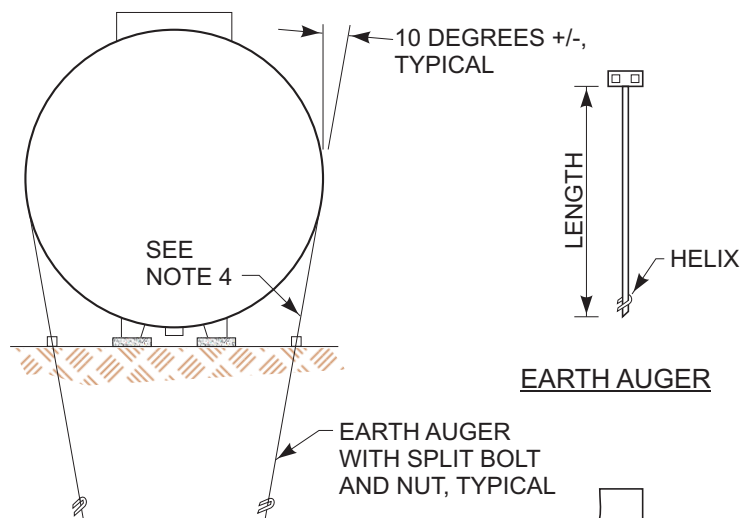

**EARTH AUGER**

**CROSS SECTION**

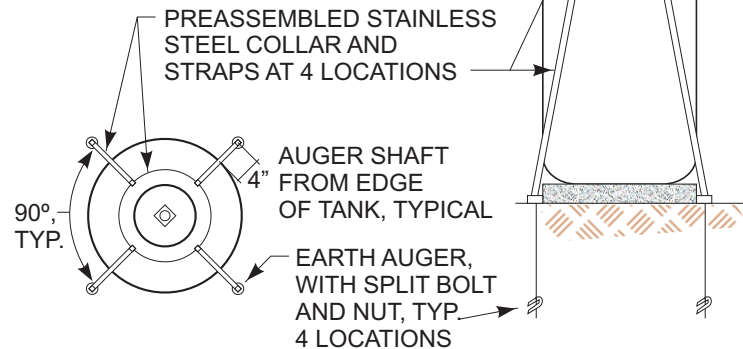

**BOTTLE TYPE TANK  
PLAN VIEW**

**BOTTLE TYPE TANK  
ELEVATION**

**NOTES**

- PRIOR TO INSTALLING THE EARTH AUGERS, CHECK FOR UNDERGROUND UTILITIES.
- THE EARTH AUGERS AND STRAPS SHOWN HEREON ARE DESIGNED TO RESIST THE BOUYANCY FORCES FROM AN EMPTY TANK FULLY SUBMERGED, AND THE LATERAL FORCES GENERATED FROM SEISMIC ZONE 4 ACTIVITY.
- EARTH AUGER TYPES AND LENGTHS REQUIRED ARE DEPENDANT UPON THE EXISTING SOIL CONDITIONS:
  - ALL CLASS 5 SOILS (CLAY, SANDY CLAY, SILTY CLAY AND CLAYEY SILT) AND SAND, SILTY SAND AND CLAYEY SAND OF THE CLASS 4 SOILS REQUIRE EARTH AUGERS OF MINIMUM 48 INCHES IN LENGTH AND (1) 6 INCH DIAMETER HELIX.
  - CLASS 4 AND BETTER SOILS WITH THE EXCEPTION OF SAND, SILTY SAND, AND CLAYEY SAND REQUIRE EARTH AUGERS OF MINIMUM 32 INCHES IN LENGTH AND (2) 4 INCH DIAMETER HELICES.
  - EARTH AUGERS SHALL HAV A TESTED MINIMUM PULL OUT VALUE OF 6000 LBS.
- STRAPS SHALL BE ONE OF THE FOLLOWING:
  - 1-1/4"x0.031" STAINLESS STEEL, 301-1/4 HARD, MINIMUM TENSILE STRENGTH OF 4750 LBS
  - 1-1/4"x0.031" GALVANIZED STEEL, CLASS B, GRADE 1, MINIMUM TENSILE STRENGTH OF 4750 LBS.
- IN THE EVENT EARTH AUGERS ARE PRECLUDED FROM INSTALLATION, ALTERNATE TETHERING DESIGNS CAN BE SUBMITTED FOR CONSIDERATION.
- IN ALL CASES, WHEN TANKS UP TO 350 GALLONS ARE PLACED IN AREAS OF SOIL TYPES AS DESCRIBED IN NOTE 3a, 2 STRAPS AND 4 EARTH AUGERS ARE REQUIRED. EARTH AUGER SIZE IS AS NOTED IN 3-a.
- MINIMUM DISTANCES OF TANKS FROM STRUCTURES AND PROPERTY LINES:

**CHAPTER 61 CALIFORNIA FIRE CODE**

Distance from buildings and property lines based on size of LPG container capacity.

SIZE	UNDERGROUND	ABOVEGROUND
0-125	10	5 with conditions
125-500	10	10
501-2000	10	25
2001-30,000	50	50
All others see CFC Table		

- Earth Augers are required in areas subject to flooding. All others may be bolted or cable tied to a concrete slab seismic only. Per CFC

**SEISMIC STABILIZATION & SEPARATIONS**

**FIRE SAFE STANDARDS**

**SONOMA COUNTY  
FIRE AND EMERGENCY SERVICES DEPARTMENT**  
2300 COUNTY CENTER DR  
Santa Rosa, California 95403  
Telephone (707) 565-1152 Fax (707) 565-1172

NOT TO SCALE	<b>F16</b>
SCALE	
01/19/17	
REVISION DATE	DRAWING NO



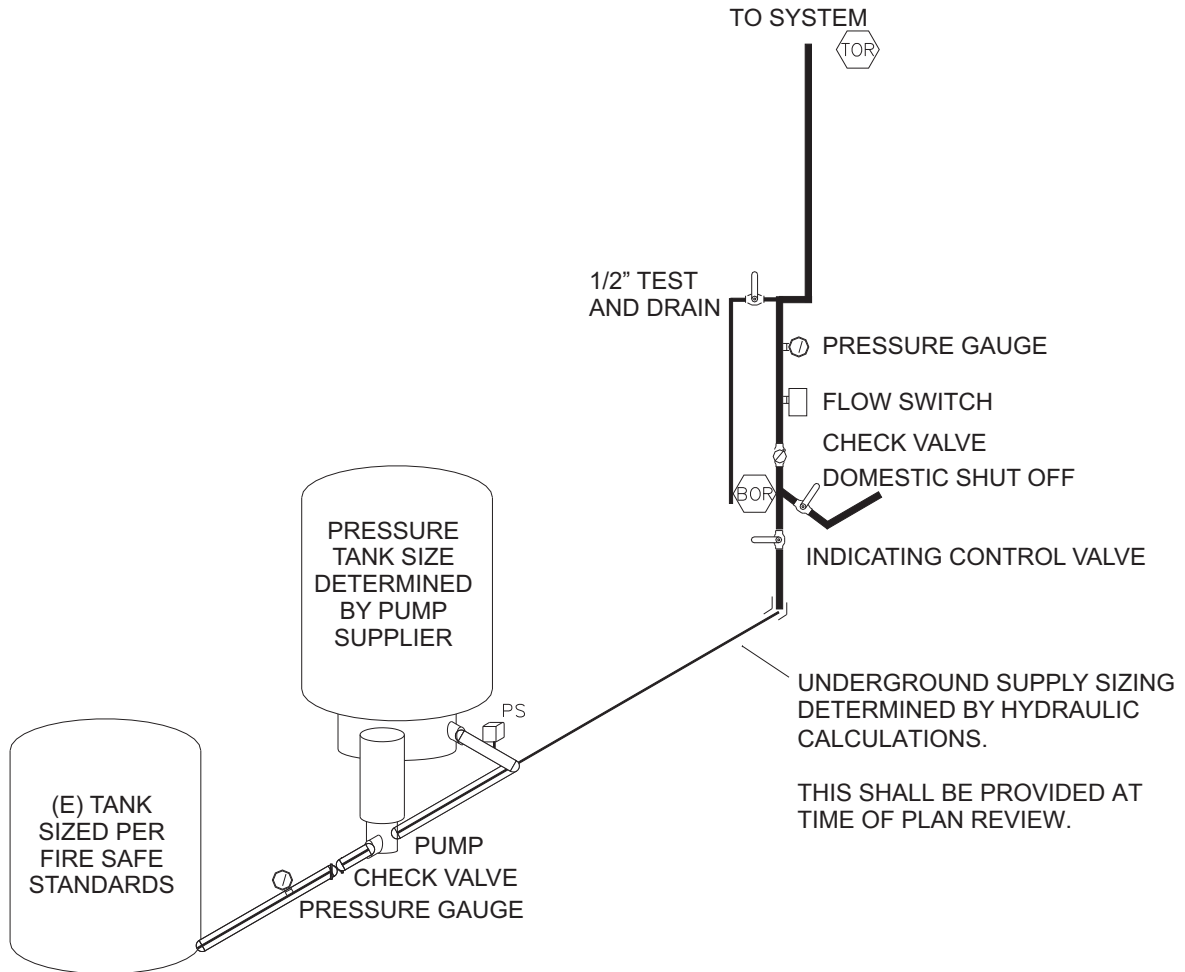

PUMP & RISER DETAIL

NFPA 13-D

**GUIDELINE FOR 13-D PUMP/TANK ASSEMBLY**

**FIRE SAFE STANDARDS**

**SONOMA COUNTY**  
**FIRE AND EMERGENCY SERVICES DEPARTMENT**  
 2300 COUNTY CENTER DR  
 Santa Rosa, California 95403  
 Telephone (707) 565-1152 Fax (707) 565-1172

NOT TO SCALE

SCALE

01/19/17

REVISION DATE

**F17**

DRAWING NO